

# CURBSIDE CLEANUP

Curbside Cleanup is only available to single-family homes and some townhomes. Eligible residents will see "Citywide Curbside Cleanup" on their utility bills. Prepare for your Cleanup day by setting your materials at the curb **before 7 a.m.** Items must be boxed or bundled with twine. **No plastic bags will be accepted.** Remember, trucks pass through only once.

**Seniors or residents with disabilities** who need help moving things to the curb can contact

Human Services at least two weeks prior to their scheduled pickup date at 952-563-4636 or TTY only 952-563-8740. For more information, visit [blm.mn/curbside](http://blm.mn/curbside). To receive email reminders, visit [blm.mn/esubscribe](http://blm.mn/esubscribe).

2018 CLEANUP SCHEDULE		
East of Portland	→	April 7
Penn to Portland	→	April 14
France to Penn	→	April 21
Normandale to France	→	April 28
West of Normandale	→	May 5

To keep program costs low, quantity limits on accepted items are enforced. Item quantity limits are specified below. Any items exceeding the specified limits will remain on the curb and residents will need to arrange for bulk material disposal. Excess materials could cost you more. To report illegal dumping or scavengers making a mess, call 911.

## QUESTIONS? CALL 952-563-8760

### ACCEPTED AT THE CURB

- General junk, household building materials, lumber, windows and doors:** Pile limited to what fits in ONE level standard-size pickup truck bed. Lumber stacked and no longer than five feet. **NO railroad ties. NO business materials used for contractor work.** General junk must be boxed or bundled with twine and weigh under 100 pounds per item.

- Carpets/pads:** Rolled and securely tied with twine. Under five feet long and one foot in diameter.

- Appliances:** Water heaters and softeners, microwaves, washers, dryers, stoves, air conditioners, dehumidifiers, freezers, dishwashers, trash compactors, garbage disposals, water coolers, refrigerators (remove door or tie securely shut). **Limit of two appliances per house. DO NOT set out appliances until the morning of your pickup date.**

- Unusable furniture:** Disassemble or tie down hide-a-way sofa beds so they cannot open when handled. Limit: two.

- BUNDLED brush:** Branches must be smaller than three inches in diameter and five feet in length, tied with twine and put in bundles that can be carried by one person. Brush piles must be no more than what can fit in a standard pickup truck bed.

- Mattresses/box springs.** Item limit: two.
- Large metal ONLY:** Large scrap metal items that do not fit in the trunk of a car (swing sets, grills, bikes, treadmills, lawn mowers, snow blowers, etc.) Drain all fluids and remove tires. Smaller items should be taken to the South Hennepin Recycling and Problem Waste Drop-Off Center, 1400 West 96th Street.

### NOT ACCEPTED AT THE CURB

- Small metal.**
- Tires, batteries.**
- Tubs, sinks, toilets.**
- Exceptionally heavy and bulky items:** Pianos or organs, for example.

- Electronic items:** TVs, computers, stereos and cell phones, printers.

- Miscellaneous building items:** Contractor materials, railroad ties, treated wood, concrete, bricks or shingles (asbestos).

- Hazardous waste:** Paint, motor oil, solvents, fluorescent tubes, propane and other household chemicals.

- Organic materials:** Leaves, grass clippings, sod, stumps, logs and food waste.

- Recyclable materials:** Newspapers, cans, glass, corrugated cardboard, boxboard and plastic bottles.

For tips on how to properly dispose of items not accepted at the curb, call 612-348-3777 or visit the Green Disposal Guide on Hennepin County's website at [www.hennepin.us/green-disposal-guide](http://www.hennepin.us/green-disposal-guide).

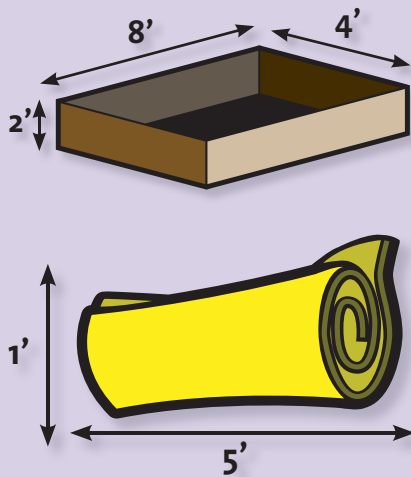

# DONATE AND RECYCLE FIRST

Before you sort your items for the Curbside Cleanup, consider donating or recycling your gently used clothing, furniture and household items. If the item is something you would give to your friend or neighbor, donate it. Doing so will divert usable and repairable items from the waste stream. Contact the organizations listed below to find out more about donating or recycling your items.

### Donate

- Arc's Value Village: visit [blm.mn/arcs](http://blm.mn/arcs) or call 952-818-8708.
- Bridging: visit [blm.mn/bridging](http://blm.mn/bridging) or call 952-888-1105.
- Choose to Reuse: visit [blm.mn/hcreuse](http://blm.mn/hcreuse).
- Savers: visit [blm.mn/savers](http://blm.mn/savers) or call 952-881-7300.
- Twin Cities Free Market: visit [blm.mn/tcfm](http://blm.mn/tcfm).

### Recycle

- Hennepin County Drop-off for Textiles: visit [blm.mn/hctex](http://blm.mn/hctex).
- Second Chance Recycling: visit [blm.mn/secondchance](http://blm.mn/secondchance).

For a full list of organizations where you can donate or recycle your items, visit our website at [blm.mn/donate](http://blm.mn/donate). Donating and recycling will help someone in need and reduce waste—a win-win situation!

### WINTER CART PLACEMENT

In the winter, it is important to place your garbage and recycling carts in an appropriate location. If there is snow or ice, shovel out a safe, accessible space and path for your carts. Place carts at least three to five feet away from other objects such as mailboxes, other carts, vehicles, trees and bushes.

## RECYCLING CALENDAR 2018

January						
S	M	T	W	T	F	S
	1	2	3	4	5	6
7	8	9	10	11	12	13
14	15	16	17	18	19	20
21	22	23	24	25	26	27
28	29	30	31			

February						
S	M	T	W	T	F	S
				1	2	3
4	5	6	7	8	9	10
11	12	13	14	15	16	17
18	19	20	21	22	23	24
25	26	27	28			

March						
S	M	T	W	T	F	S
				1	2	3
4	5	6	7	8	9	10
11	12	13	14	15	16	17
18	19	20	21	22	23	24
25	26	27	28	29	30	31

April						
S	M	T	W	T	F	S
1	2	3	4	5	6	7
8	9	10	11	12	13	14
15	16	17	18	19	20	21
22	23	24	25	26	27	28
29	30					

May						
S	M	T	W	T	F	S
		1	2	3	4	5
6	7	8	9	10	11	12
13	14	15	16	17	18	19
20	21	22	23	24	25	26
27	28	29	30	31		

June						
S	M	T	W	T	F	S
					1	2
3	4	5	6	7	8	9
10	11	12	13	14	15	16
17	18	19	20	21	22	23
24	25	26	27	28	29	30

July						
S	M	T	W	T	F	S
1	2	3	4	5	6	7
8	9	10	11	12	13	14
15	16	17	18	19	20	21
22	23	24	25	26	27	28
29	30	31				

August						
S	M	T	W	T	F	S
			1	2	3	4
5	6	7	8	9	10	11
12	13	14	15	16	17	18
19	20	21	22	23	24	25
26	27	28	29	30	31	

September						
S	M	T	W	T	F	S
						1
2	3	4	5	6	7	8
9	10	11	12	13	14	15
16	17	18	19	20	21	22
23	24	25	26	27	28	29
30						

October						
S	M	T	W	T	F	S
	1	2	3	4	5	6
7	8	9	10	11	12	13
14	15	16	17	18	19	20
21	22	23	24	25	26	27
28	29	30	31			

November						
S	M	T	W	T	F	S
				1	2	3
4	5	6	7	8	9	10
11	12	13	14	15	16	17
18	19	20	21	22	23	24
25	26	27	28	29	30	

December						
S	M	T	W	T	F	S
						1
2	3	4	5	6	7	8
9	10	11	12	13	14	15
16	17	18	19	20	21	22
23	24	25	26	27	28	29
30	31					

RECYCLE WEEK

HOLIDAY\*

\* No pickup; pickup one day later.