

- NOTES:
1. LETTERING SHALL BE UPPER AND LOWER CASE.
 2. INITIAL UPPER-CASE LETTERING SHALL BE:
 4" ON 6" BLANK (LOCAL 2-LANE STREETS 30 MPH OR LESS)
 6" ON 9" BLANK (LOCAL 2-LANE STREETS >30 MPH & MULTI-LANE)
 REFER TO MMUTCD FOR POSTED SPEEDS ABOVE 40 MPH.
 3. LETTERING SHALL BE A 'C' FONT.
 4. CORNERS EXTENDING BEYOND THE BORDER SHALL NOT BE TRIMMED.
 5. BORDER SHALL BE 0.5" WITH NO MARGIN.

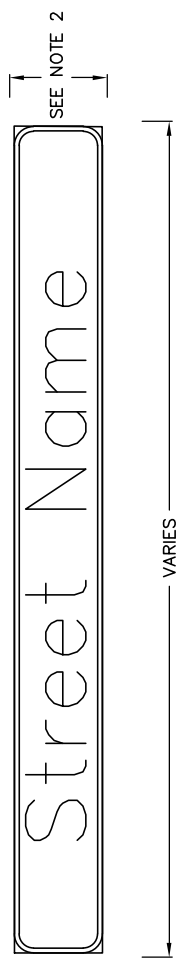

LYLE E SERIES OR GOPHER SIGN CO. U-100 SERIES BRACKET

ONE TWO-WAY SIGN (TYP).
 ADDITIONAL TWO-WAY ASSEMBLIES
 MAY BE REQUIRED AT
 MULTI-LEGGED INTERSECTIONS.

PUBLIC ROADWAYS: WHITE LEGEND
 ON GREEN BACKGROUND.

PRIVATE ROADWAYS: WHITE LEGEND
 ON BROWN BACKGROUND.

SIGN POSTS SHALL BE 2 3/8" (O.D.)
 GALVANIZED ROUND POST, 14 GAUGE
 10' IN LENGTH.

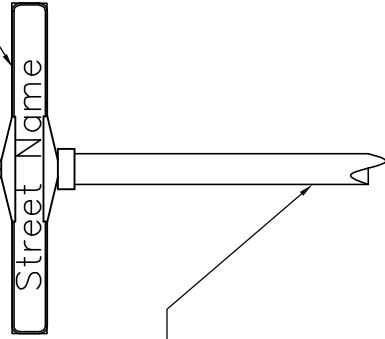

STREET_NAME_SIGN
TYPICAL

NOTES:

1. ALL TRAFFIC CONTROL DEVICES, INSTALLATION AND SIGNING SHALL CONFORM TO THE LATEST VERSION OF THE MINNESOTA MANUAL ON UNIFORM TRAFFIC CONTROL DEVICES (MMUTCD).
2. SIGN SHEETING AND LEGEND SHALL BE HIGH INTENSITY PRISMATIC (HIP).
3. SIGN PANEL LEGEND AND BACKGROUND COLOR SHALL BE IN ACCORDANCE WITH THE STANDARD SIGN DRAWINGS OF THE MNDOT STANDARD SIGNS MANUAL, UNLESS PROVIDED FOR OTHERWISE IN THE STANDARD SPECIFICATIONS FOR TRAFFIC CONTROL SIGNAL DEVICES.
4. MOUNTING HEIGHT: MINIMUM 7' FROM FINISHED GROUND TO BOTTOM OF SIGN.

703 - SIGN_GROUND_MOUNT_STREET_NAME
 703 - SIGN_GROUND_MOUNT_STREET_NAME.DWG 9/2016